



## Montageanleitung

### Mounting instruction

## H0 LIEBHERR LG 1550 BREUER & WASEL

### H0 LIEBHERR LG 1550 BREUER & WASEL

(DE)

1. Wichtige Hinweise ..... 1
2. Inhalt..... 2
3. Montage ..... 6

(EN)

1. Important information ..... 1
2. Contents ..... 2
3. Mounting ..... 6

### Tampon-Bedruckung

#### Pad printing



Viele Fahrzeug-Modelle und andere Bausätze von Kibri werden im Tampondruckverfahren bedruckt. Die Druckfarbe wird bei diesem Verfahren durch einen elastischen Tampon aus Silikon-Kautschuk auf das Modell übertragen. Many vehicles and other model kits of Kibri are high quality pad printed. The printing is transferred to the model with an elastic pad of silicone rubber.

Die aktuelle Version der Anleitung finden Sie auf der Kibri-Homepage unter der Artikelnummer.

You will find the latest version of the manual on the Kibri website using the item-No.

**Änderungen vorbehalten. Keine Haftung für Druckfehler und Irrtümer.**

Subject to change without prior notice. No liability for mistakes and printing errors.



**Viessmann Modelltechnik GmbH**  
Bahnhofstraße 2a  
D - 35116 Hatzefeld-Reddighausen  
info@viessmann-modell.com  
+49 6452 9340-0  
www.viessmann-modell.de

**Schwierigkeitsgrad  
der Bausätze:**  
Level of difficulty:

Made in Europe



88945  
Stand 02/sw  
01/2021  
Szt

(DE)

### 1. Wichtige Hinweise

Bitte halten Sie beim Zusammenbau unbedingt die Reihenfolge der Bauabschnitte ein!

#### Sicherheitshinweise

 **Vorsicht**

#### Verletzungsgefahr!

Aufgrund der detaillierten Abbildung des Originals bzw. der vorgesehenen Verwendung kann das Produkt Spitzen, Kanten und abbruchgefährdete Teile aufweisen. Für die Montage sind Werkzeuge nötig.

#### Montage des Bausatzes

Die beim jeweiligen Montageschritt benötigten Teile trennen Sie bitte mit einem Seitenschneider bzw. Modellbaumesser vorsichtig vom Spritzbaum ab und entgraten die Ränder.

Da Spritzlinge für mehrere Artikel verwendet werden, kann es sein, dass bei diesem Bausatz einige Teile übrig bleiben.

Dieser Bausatz wurde sorgfältig geprüft und verpackt. Sollte es trotzdem einmal vorkommen, dass ein Teil fehlt, fordern Sie dieses bitte per E-Mail oder per Post bei uns an. Bitte nennen Sie uns die Bezeichnung und Artikel-Nummer des Bausatzes sowie Spritzling- und Teile-Nr. Diese Angaben finden Sie in der Montageanleitung. Sie erhalten dann umgehend von uns Ersatz.

Passenden Kleber für die Bausätze finden Sie im Kibri Sortiment.

(EN)

### 1. Important information

Please observe the correct sequence when assembling the parts to sub-assemblies and to the completed product!

#### Safety information

 **Caution:**

#### Risk of injury!

Due to the finely detailed reproduction of the original and the intended use, this product may have sharp points or edges as well as parts that may easily break off. Some tools are required for assembly.

#### Assembly

Carefully separate the parts required for the respective assembly phase with a side cutter or a sharp utility knife from the injection-moulded sprue and deflash the edges.

Since some sprues are used for several different products it is quite possible that some parts may not be needed for this particular product.

The contents of this kit have been carefully checked against the parts list. However, should a part be missing please contact us by e-mail or by sending a letter. Please state the precise product description and the item-No. as well as the No. of the sprue and the specific part that is missing. You will find all necessary information in this manual. We will promptly supply the missing parts.

You will find suitable glue for the kits in the Kibri product range.

## 2. Inhalt

Kontrollieren Sie nach dem Auspacken den Lieferumfang auf Vollständigkeit:

- Bedruckte Bauteile, Teile-Nr. 1, 20, 22, 40 (2x), 42 (2x), 46 (4x), 46A (4x), 60, 61, 62, 85,
- Schraube M4x10
- Mutter M4
- 22 Ballastgewichte
- 30 m Faden
- Anleitung

## 2. Contents

Check the contents of the package for completeness after unpacking:

- Printed parts, part-No. 1, 20, 22, 40 (2x), 42 (2x), 46 (4x), 46A (4x), 60, 61, 62, 85
- Screw M4x10
- Nut M4
- 22 counterweight
- 30 m string
- Manual

Teil-Nr.	Stück	Teil-Nr.	Stück	Farbe
716	1	1176	13	Blau/Blue
736	1	1176	4	Weiß/White
1148	1	1406	2	
1150	2	1409	1	
1151	2	1410	1	
1152	1	1412	1	
1153	1	1413	1	
1154	1	1415	1	
1155	1	1416	1	
1156	1	1417	1	
1158	4	1418	1	
1159	4	1419	2	
1160	1	1420	1	
1162	1	1421	1	
1163	1	1422	2	
1164	4	1423	2	
1165	1	1424	2	
1166	1	1426	2	
1167	1	1427	2	
1168	1	1428	1	
1169	1	1429	2	
1174	1	1627	1	
1175	1			

### DE

Hochauflösende Druckvorlagen für Beschriftungen und Beschriftungen finden Sie auf unserer Homepage [www.kibri.de](http://www.kibri.de) im Download Center. Die Dekobögen lassen sich auf einem handelsüblichen Farbdrucker ausdrucken. Für den jeweiligen Druckertyp (Tintenstrahl oder Laser) geeignetes Papier bzw. Folie gibt es im Schreibwaren-fachhandel. Ideal sind selbstklebende, glatte Papiere oder Folien mit geringer Materialstärke.

**Ausdrucken – ausschneiden – aufkleben – fertig!**

[dekobogen.kibri.de](http://dekobogen.kibri.de)

Kataloge von Messmann und Kibri/Vollmer können auch bequem über das Internet angefordert werden. Folgen Sie dazu einfach diesem Link bzw. scannen Sie den QR-Code.

Catalogues by Messmann and Kibri/Vollmer can be ordered alternatively via Internet. Please follow the link or use QR-code.

### EN

The high-resolution master copy for all kind of signs in your Kibri kit are available as download for free. Deco sheets can be printed by using a standard colour printer. Suitable paper or foil for the respective printers are offered by specialized trade. Best way is to use self-adhesive smooth papers or foil with low material thickness.

**Print – cut – stick – ready!**

[katalogversand.kibri.de](http://katalogversand.kibri.de)

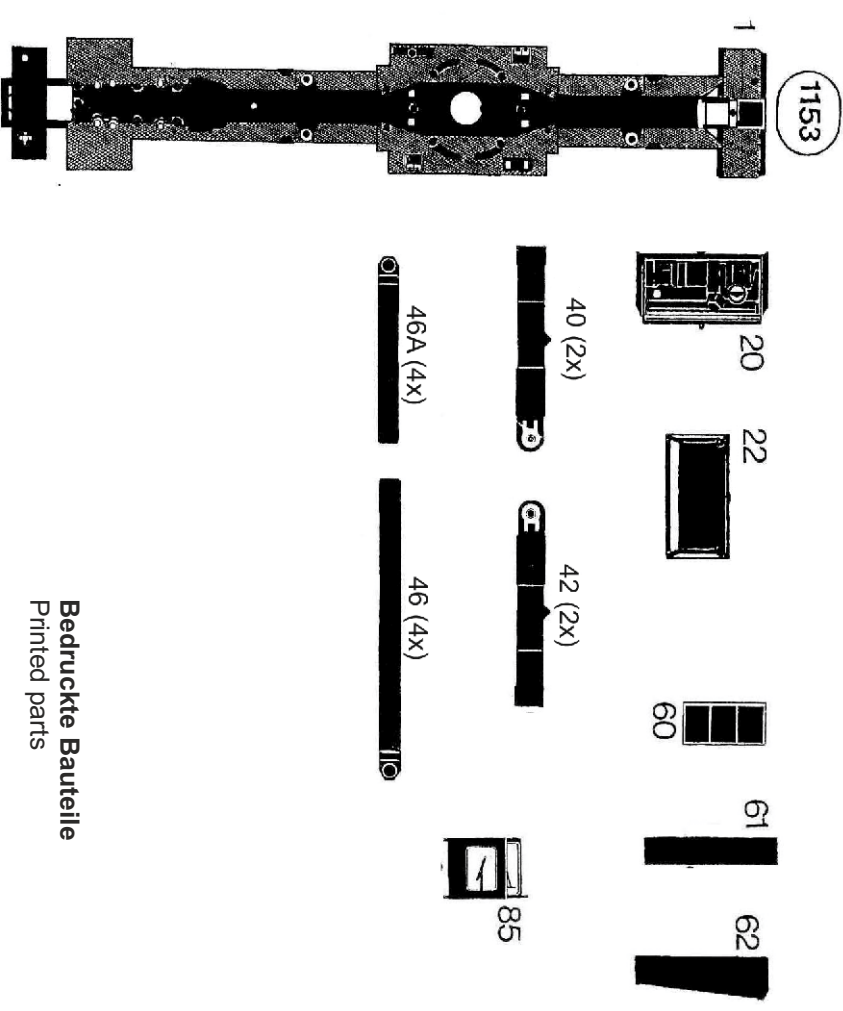

**Bedruckte Bauteile**  
Printed parts



Schaukästen von **Kibri** ...  
für jede Situation die passende Lösung!  
Wooden displays from **Kibri** ...  
the right solution for every situation!

Weitere Vitrinen finden Sie in unserem Katalog oder auf [www.kibri.de](http://www.kibri.de).  
Further displays you will find in our catalogue or at [www.kibri.de](http://www.kibri.de).

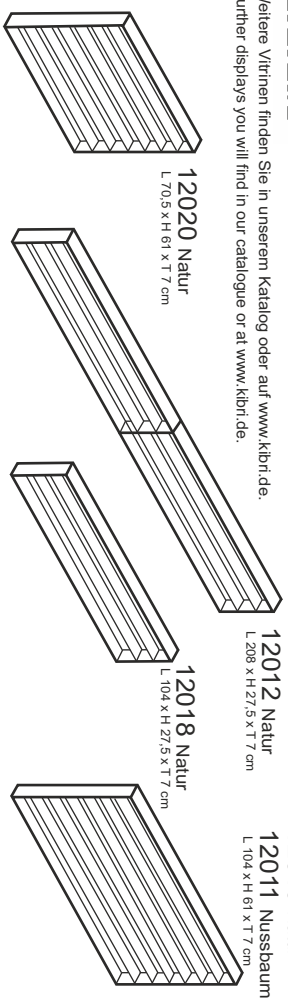

88945/13061

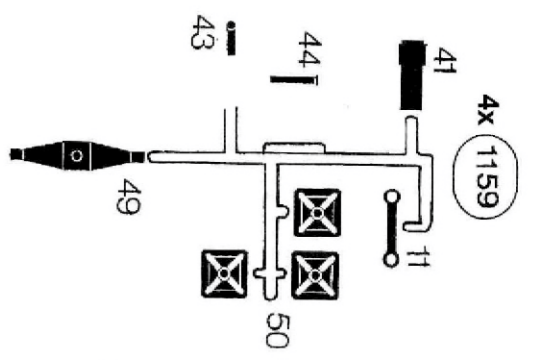
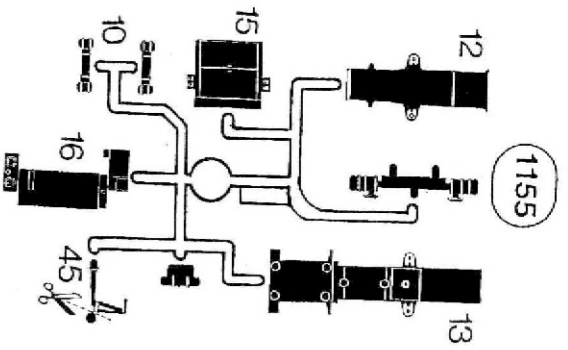
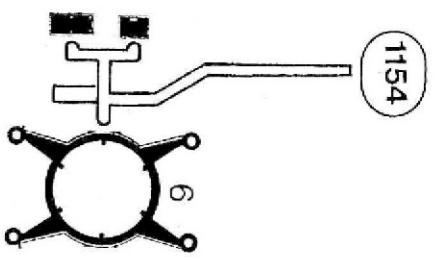
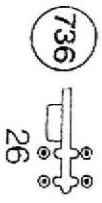
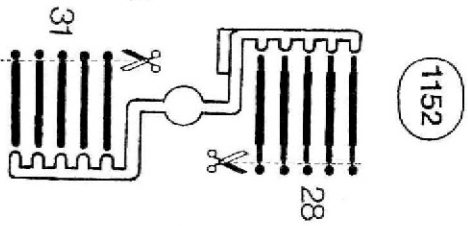
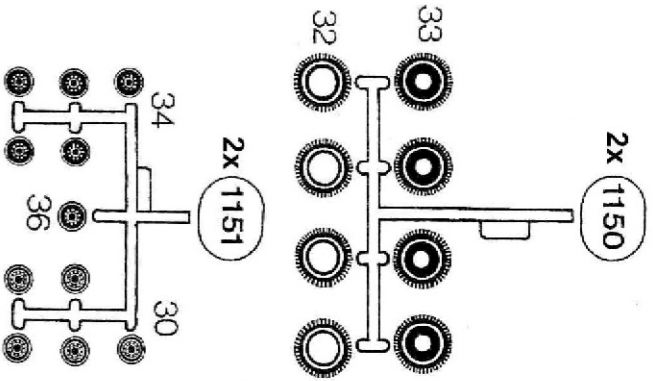
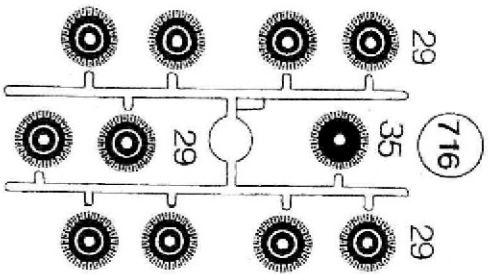

1160

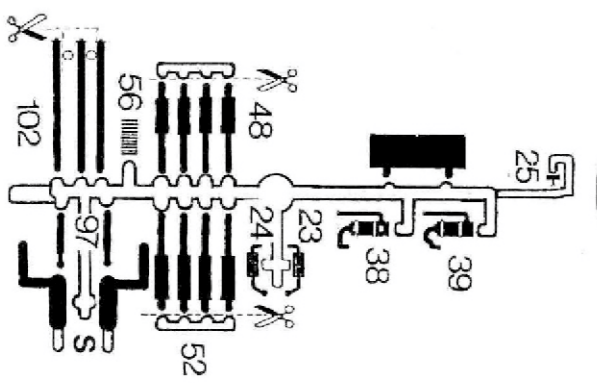

1156

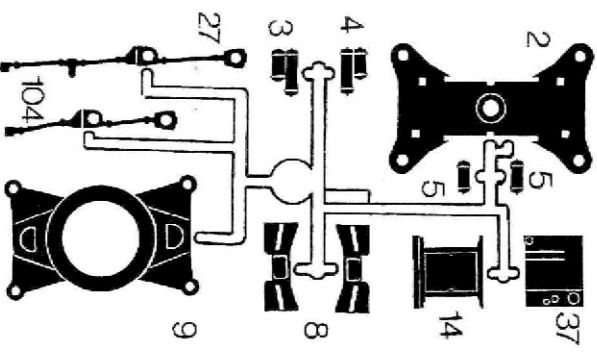

1148

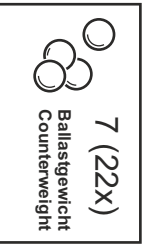
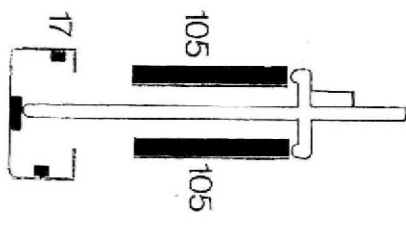

4x 1158

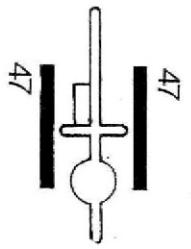

1162

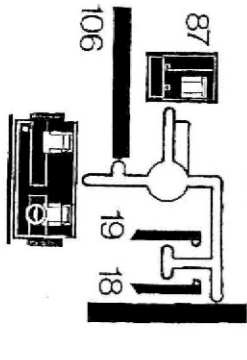

4x 1164

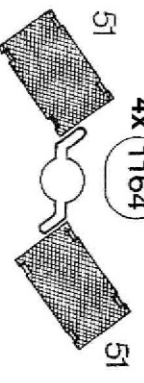

1627

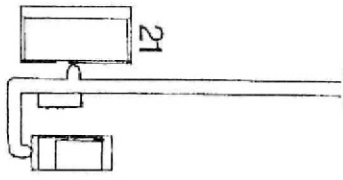



Faden  
String

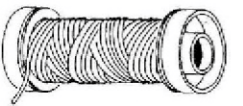

1167

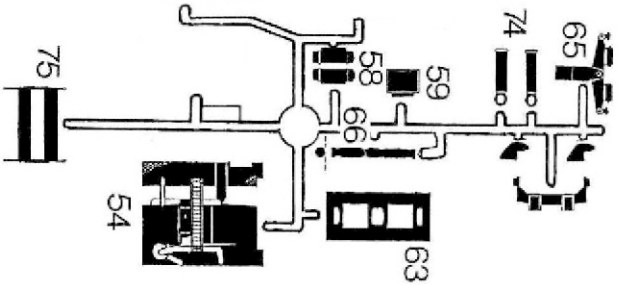

1165

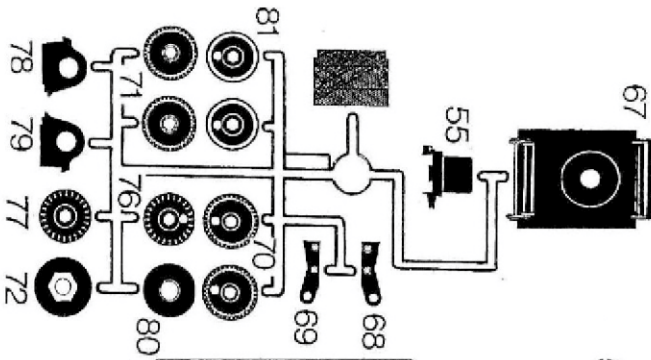

1166

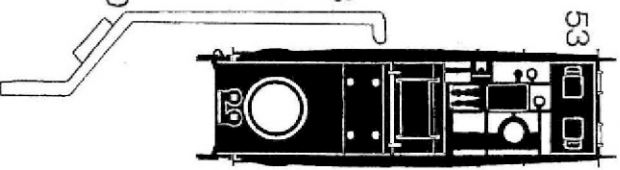

1168



1174

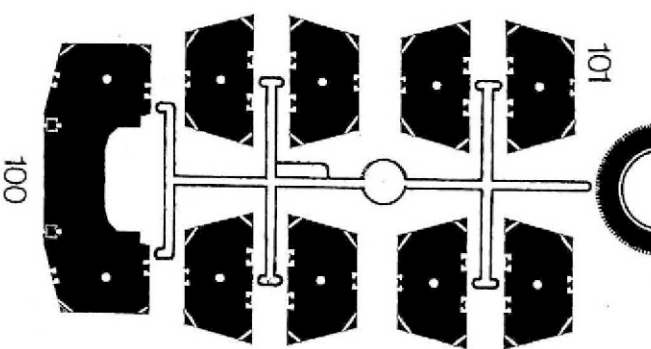

1415

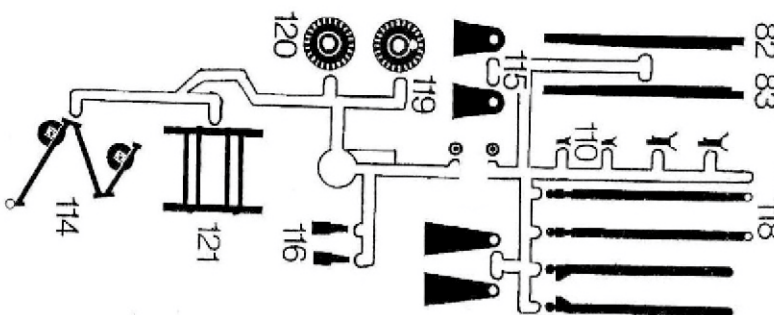

1163

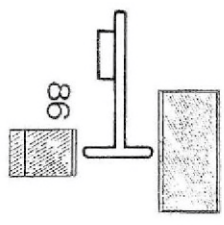

4x  
1176  
Weils  
White



13x  
1176  
Blau  
Blue

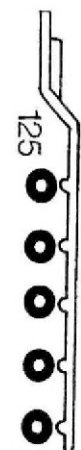

1169

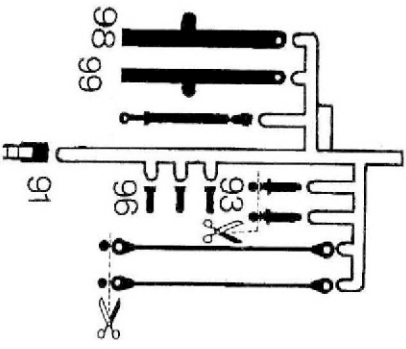

1175

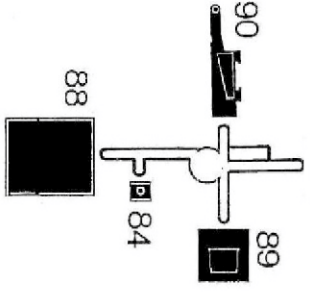

2x  
1406

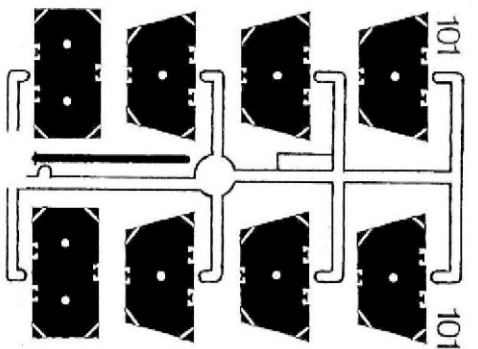

2x  
1427

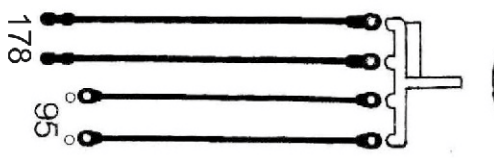

1412

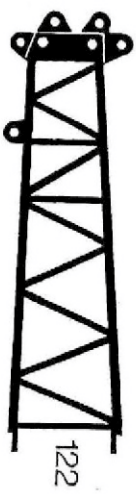

1413



2x 1419

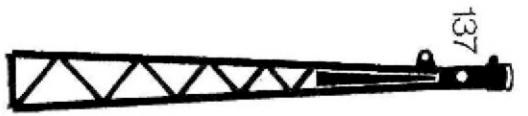

1409

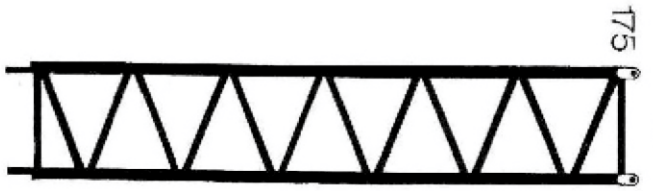

1410



1416



1424

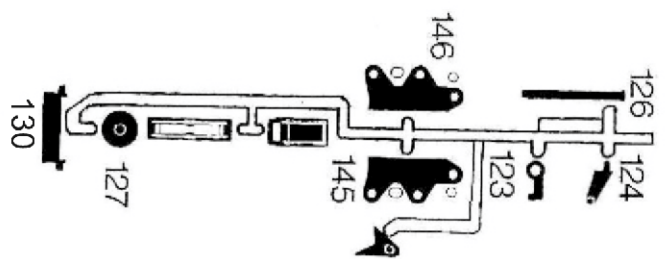

1418

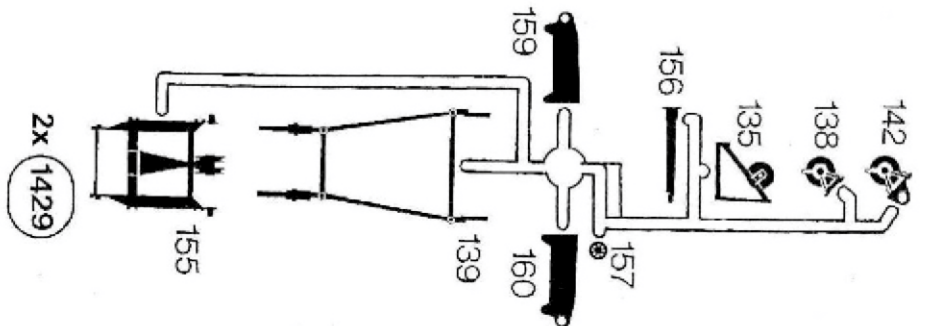

1417



1420



1421



2x 1422

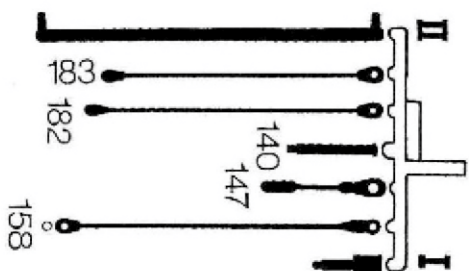

2x 1423

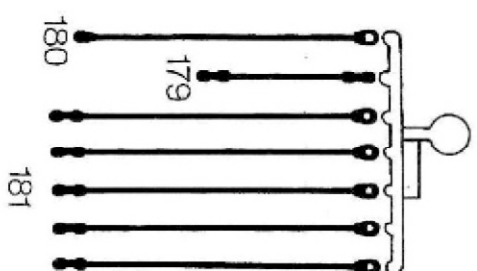

2x 1426

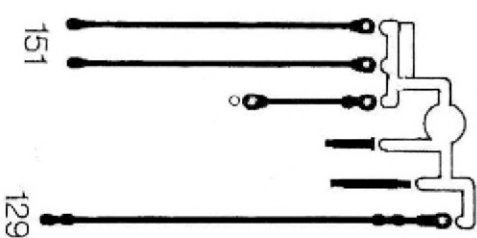

1428

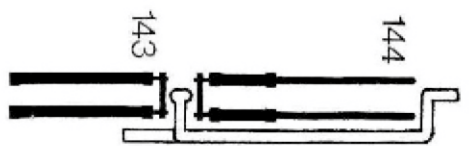

2x 1429

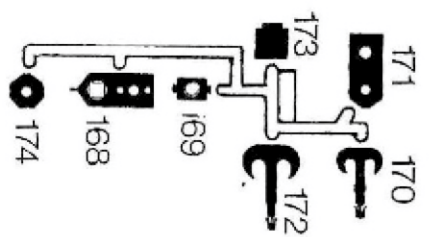



### 3. Montage Mounting

1

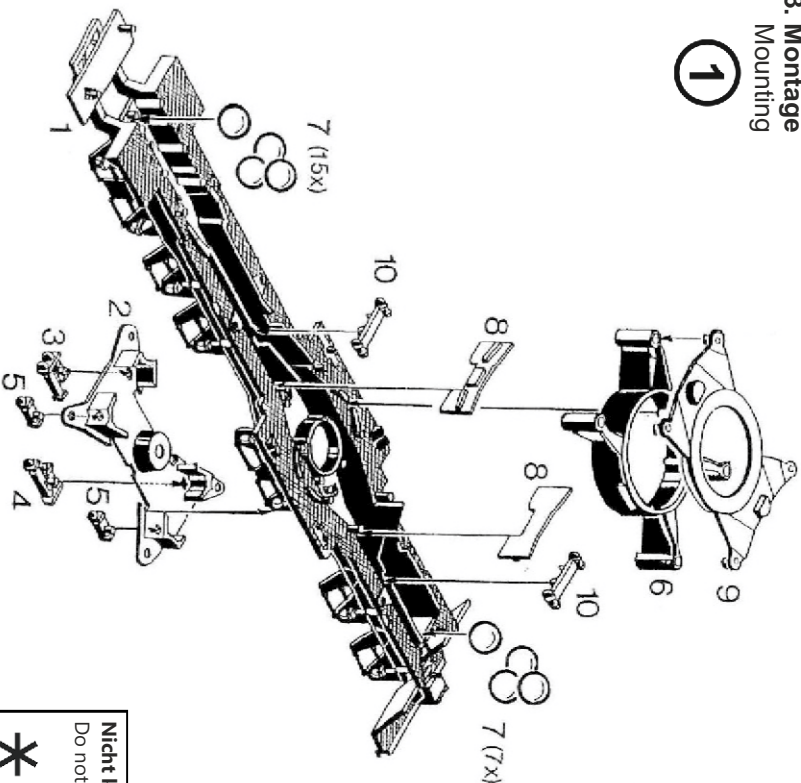

**\* Nicht kleben**  
Do not glue

2

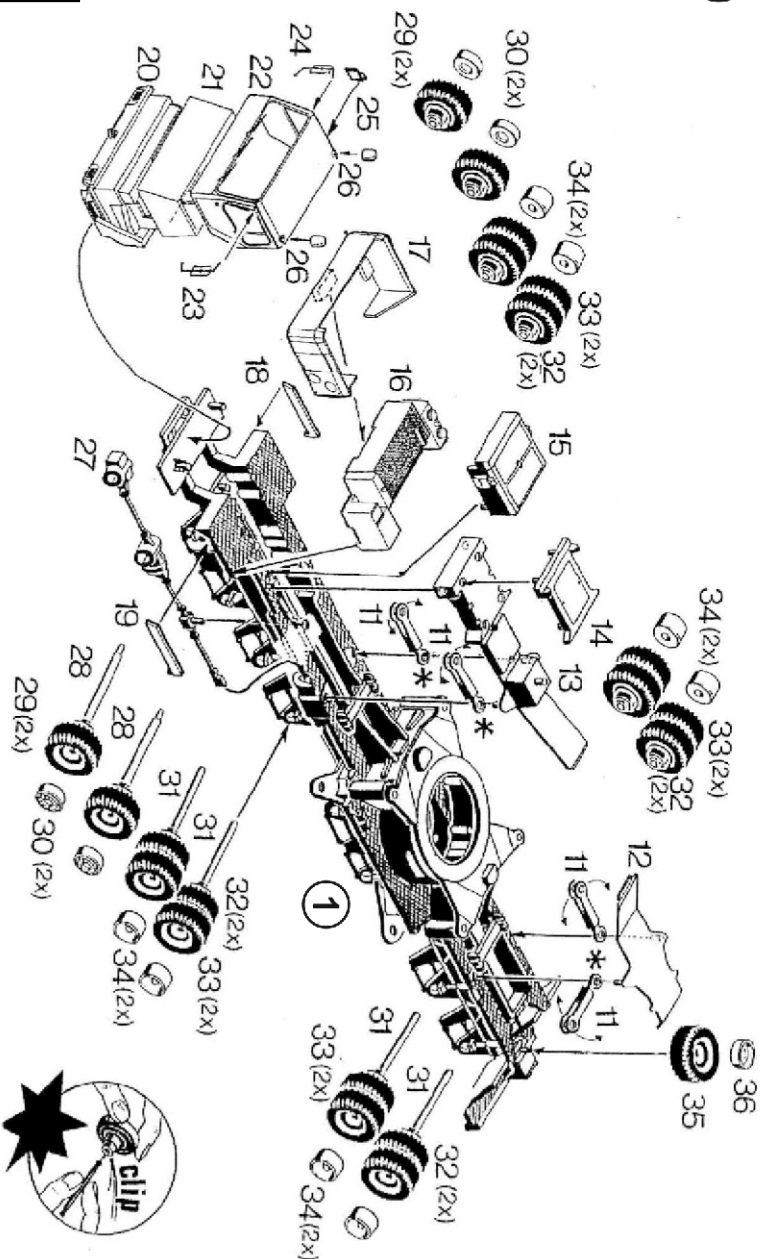

3

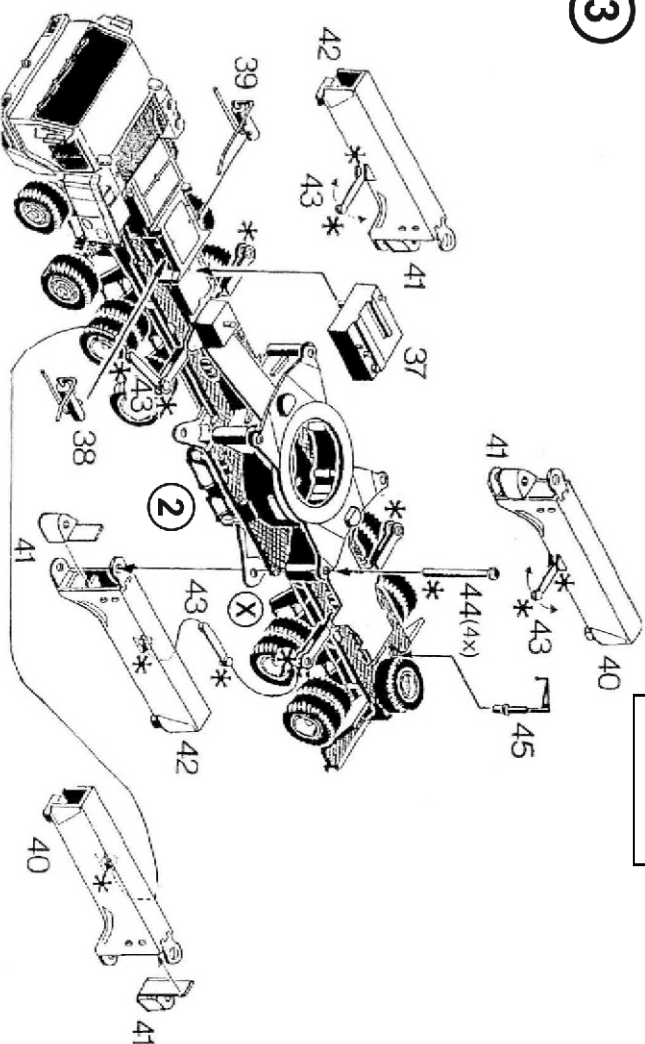

4

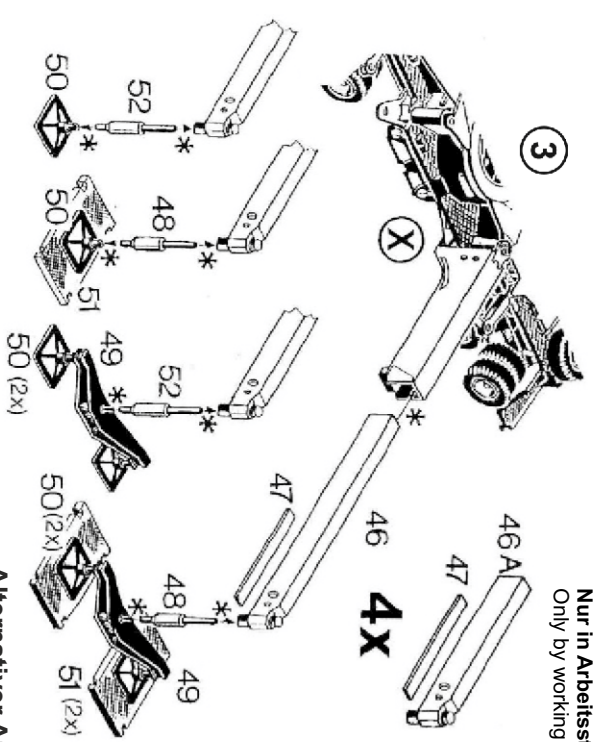

Nur in Arbeitsstellung  
Only by working position

Alternativer Aufbau  
Alternative mounting



5

Faden 2 (800 cm / 315")  
String

Faden 3 (600 cm / 236")  
String

Faden 4 (300 cm / 118")  
String

Faden 1 (400 cm / 157")  
String

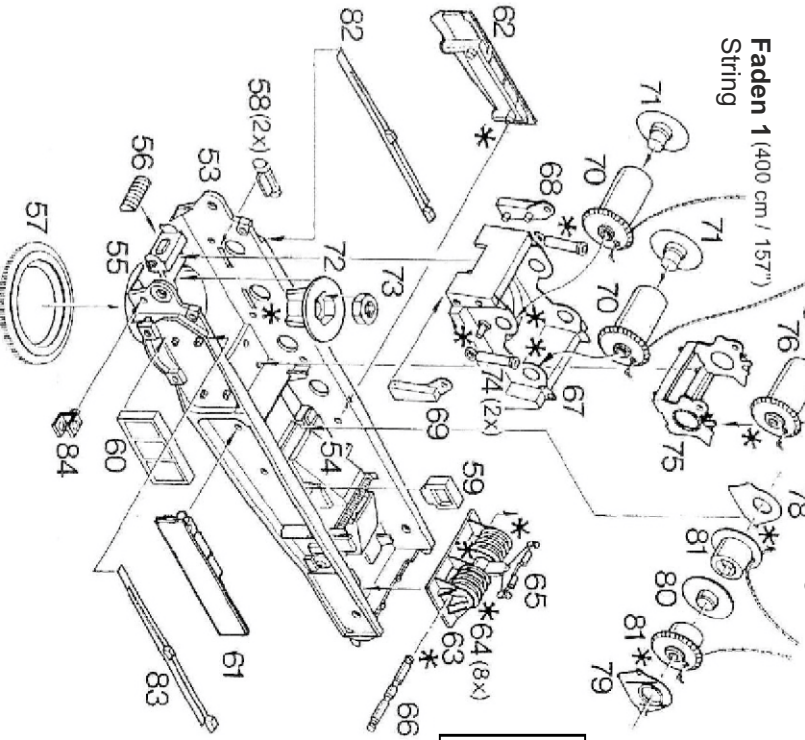

**Nicht kleben**  
Do not glue

8

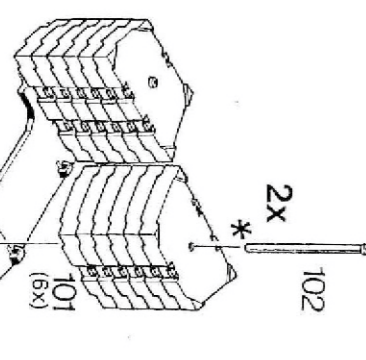
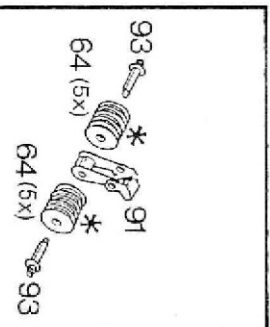

6

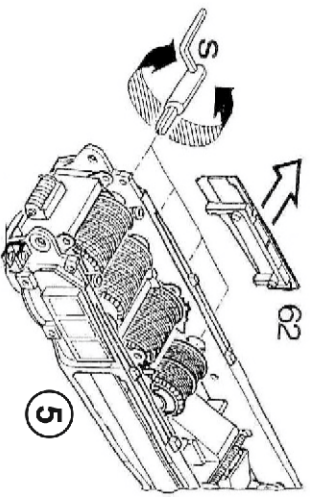

7

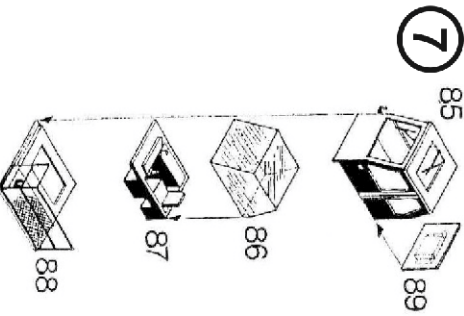

88945/13061

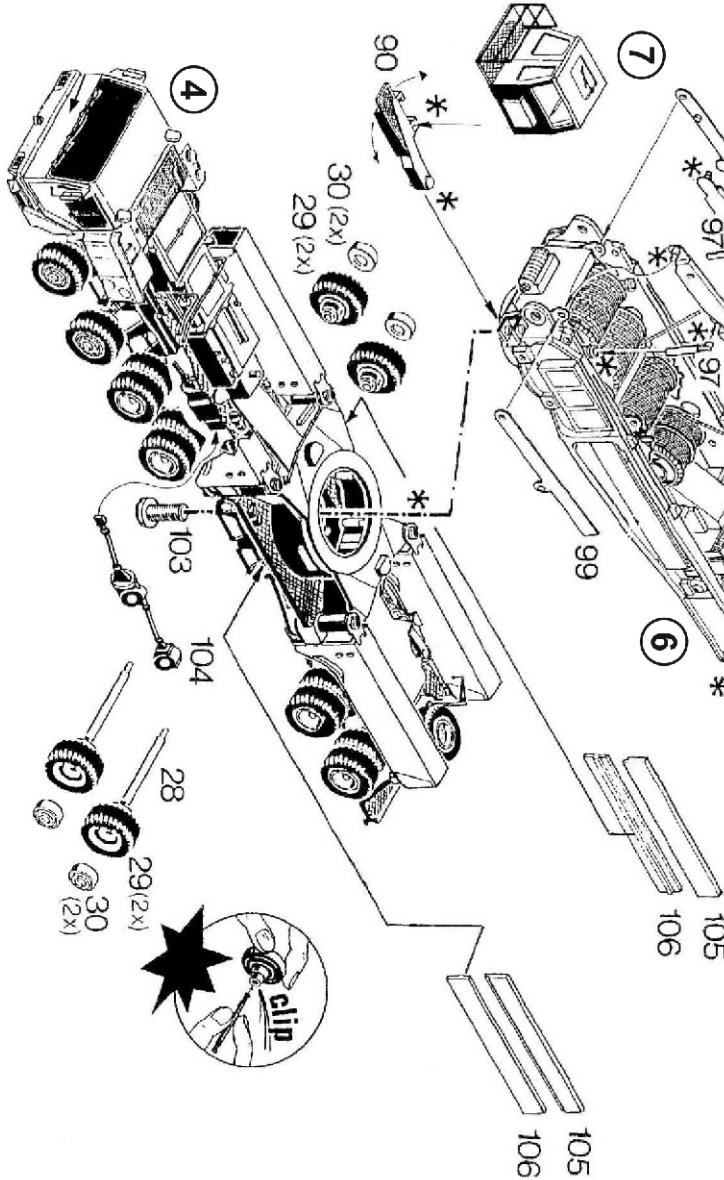

9

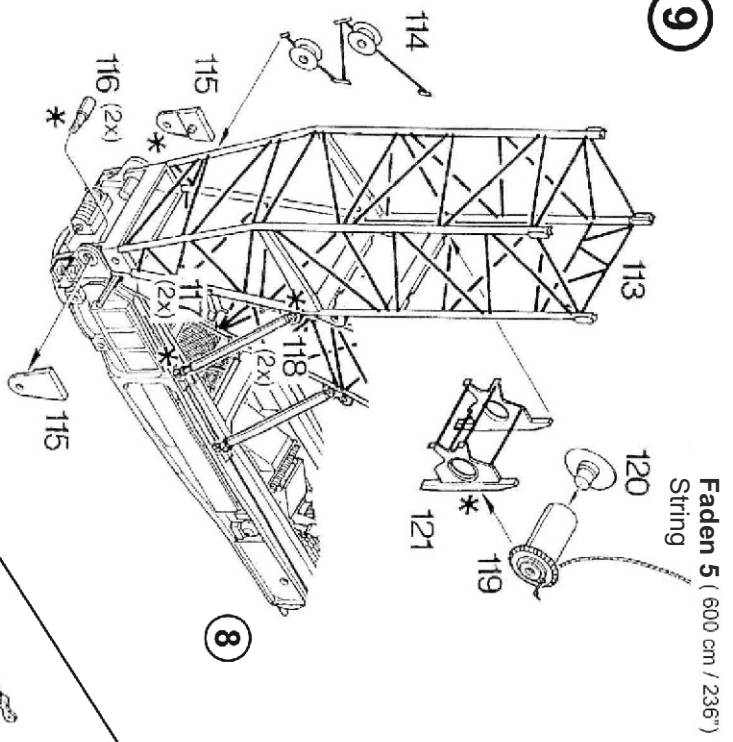

8

10

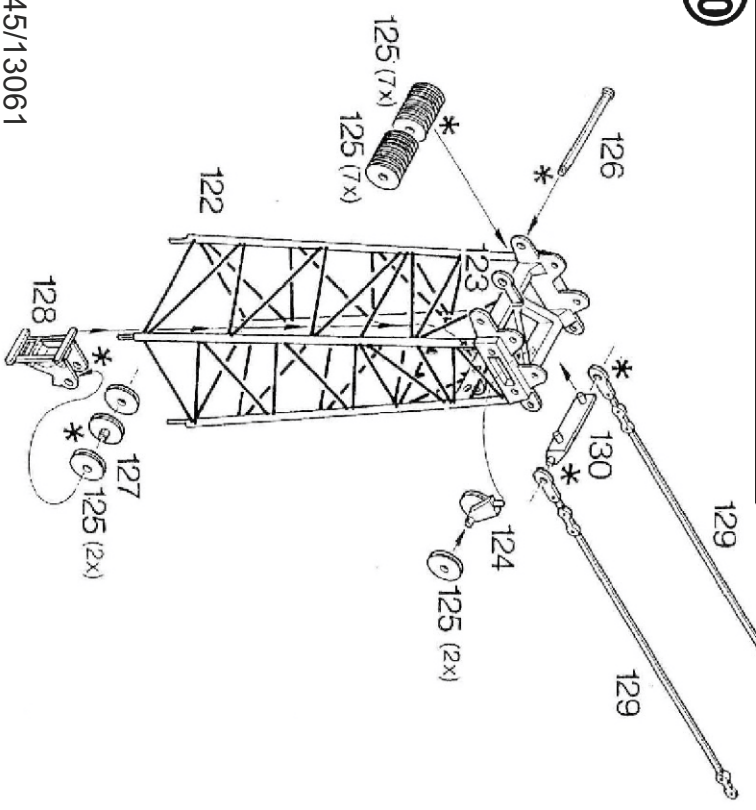

**\* Nicht kleben**  
Do not glue

11

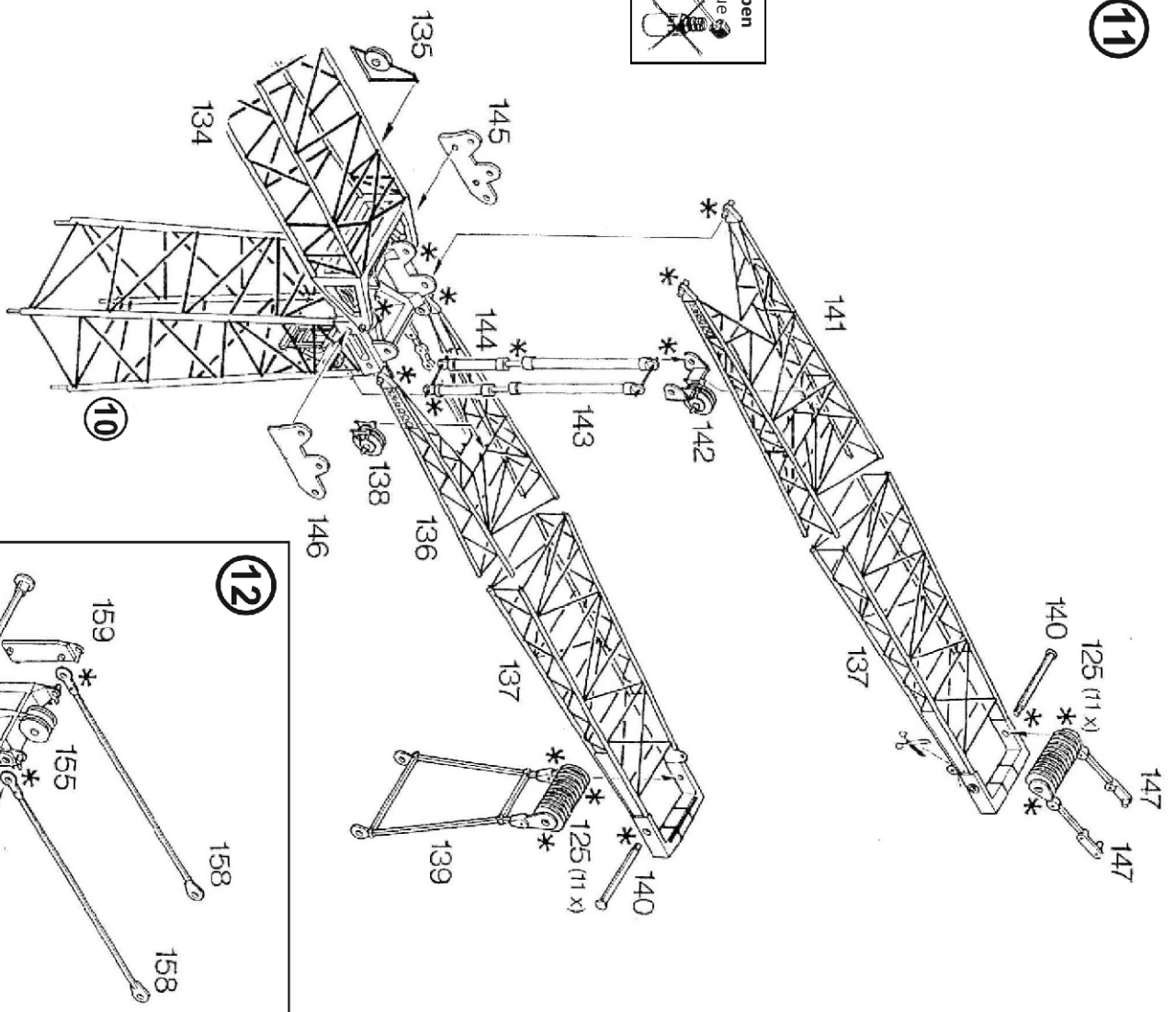

12

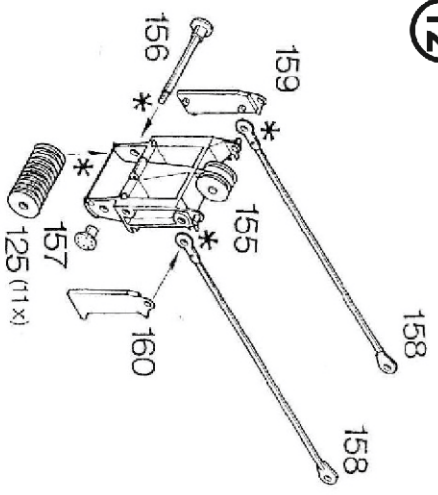



**II** Halterung zur Seilmontage  
Supporter for ropemounting

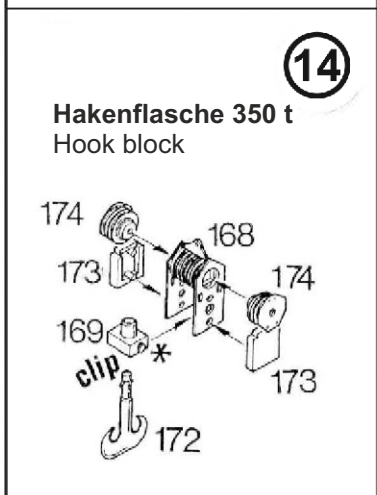
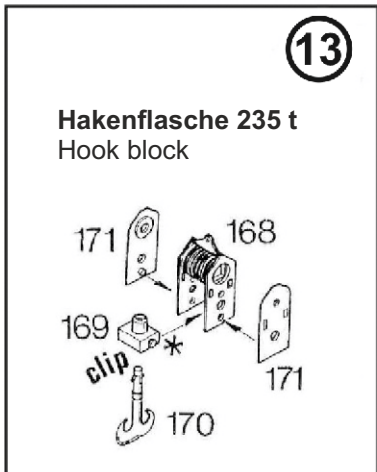
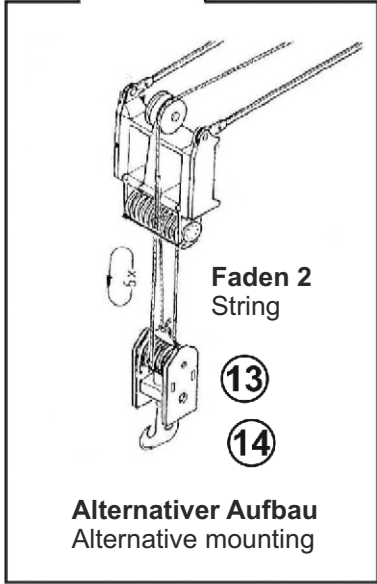
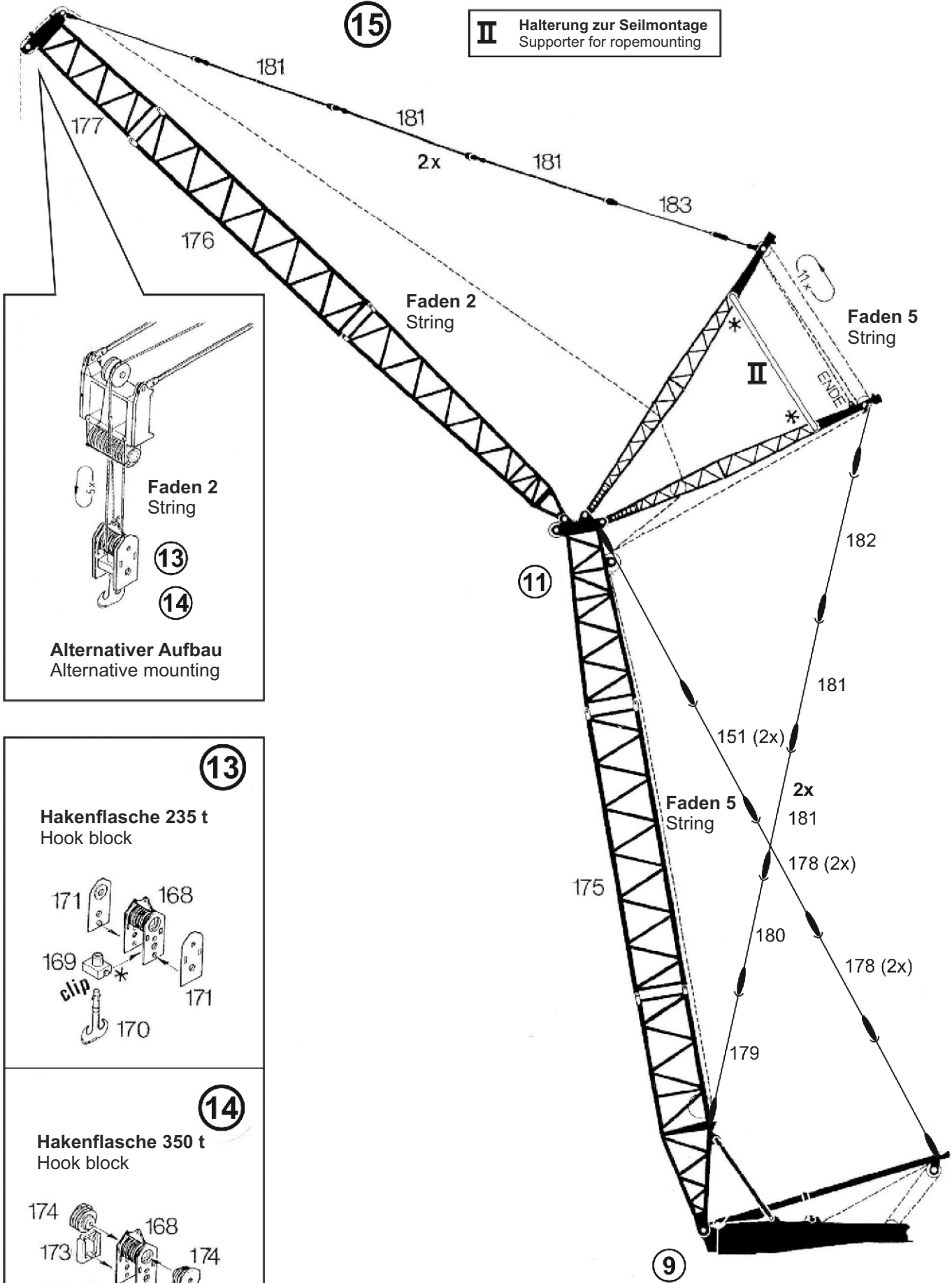

**Nicht kleben**  
Do not glue

\*